



22743 Freepoint Road
Sterling, IL 61081

Item #140

Louvered Tailgate

Rev 010111

Caution: Small Parts. Not recommended for children under 12 yrs of age. Use Care when handling – sharp edges. Use of this item in its intended purpose may violate the safety standards of the original item for which it is intended to be used with.

The TractorFab louvered goose-neck tailgate is designed for the Ertl Dodge Ram Crew-Cab. With careful fitting, it should fit most 1/64 scale pick-ups, depending on casting variations.

Remove the existing tailgate with a Dremel Tool or small razor saw. File the edges smooth.

IMPORTANT: The tailgate is made tapered to match the Ertl casting. The finished opening width should be approx. 1.01" at the top, and .99" at the bottom. Removing too little material will not allow the tailgate to operate, removing too much material will not allow the tailgate pins to fit in the holes.

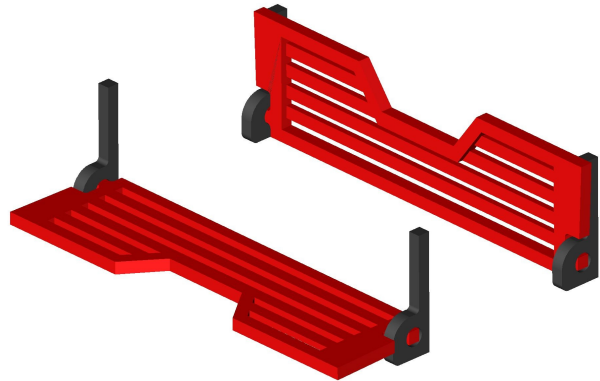

If installing on another truck, test fit as you go. If the box width is narrow, the edges of the tailgate may need to be filed down to fit. The notches around the pin will need to be notched deeper as well.

Test the operation of the hinges as shown above. File the tailgate as needed to get the correct opening angle.

Referring to the illustration above, glue the black upright pieces to the inside of the pickup box. The rear face of the tailgate should be flush with the outside of the box when glued in the correct position.

Item #138 & #143

Headache Racks

When installing one of the TractorFab headache racks, first paint the desired color, or leave silver for the Chrome look.

Determine which way you prefer the recessed portion of the racks. The recessed louvers are intended to be visible, so the flat side will go against the cab. However, they can go either way.

Apply a bead of glue to the bottom edge, and place on the front edge of the pickup body.

We recommend Duco Cement for an adhesive.

